

D

D

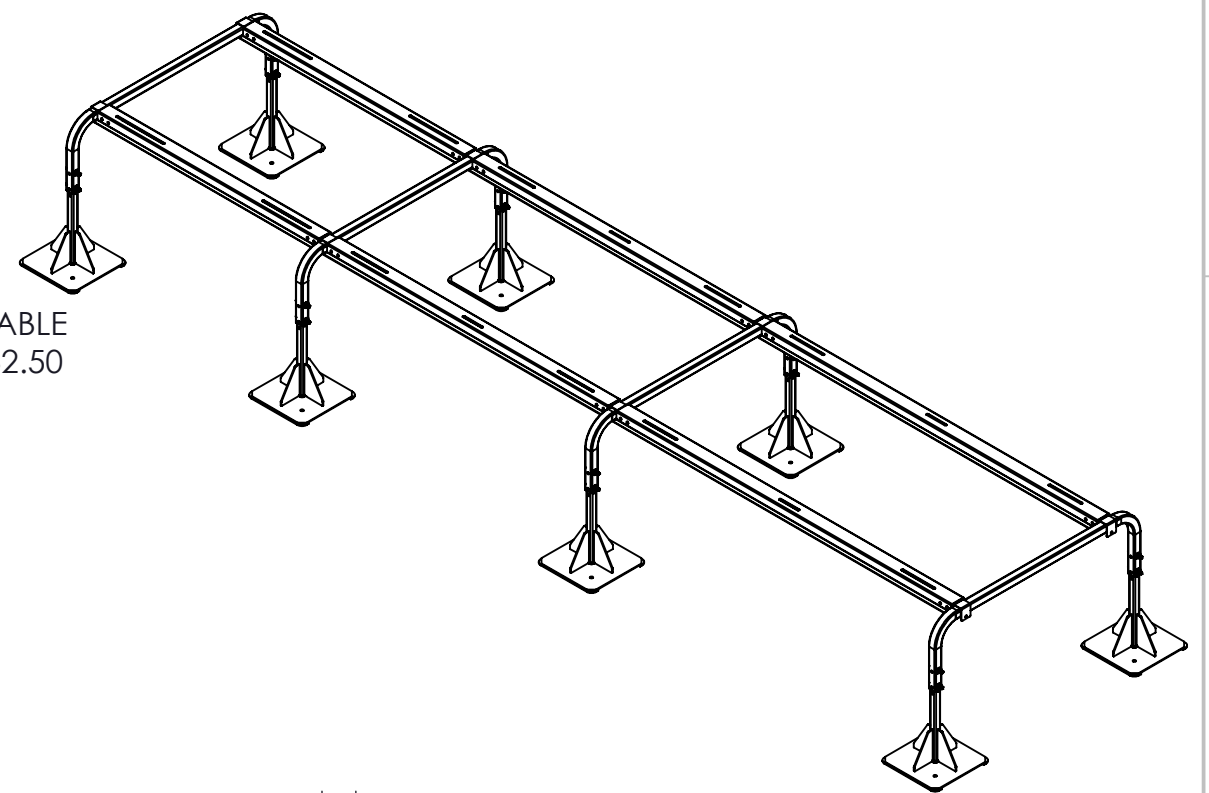
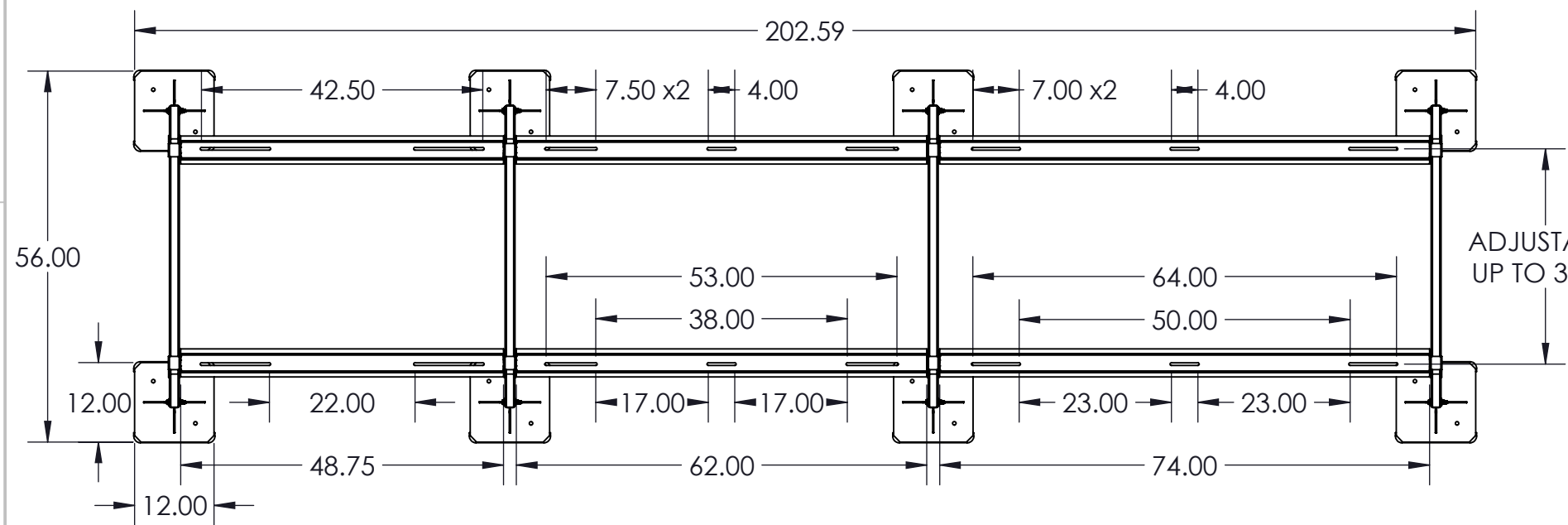

C

C

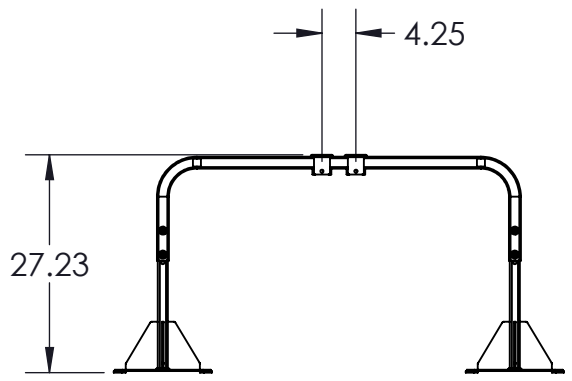

B

B

THIS UNIT CONSISTS OF:
(1) QSSB48-24
(1) QSSX62-24
(1) QSSX74-24

A

A

ALL DRAWINGS AND WRITTEN MATERIAL CONTAINED HEREIN ARE THE PROPERTY OF DIVERSITECH CORP AND MAY NOT BE DUPLICATED OR DISCLOSED AT ANY TIME UNLESS APPROVED IN WRITING BY DIVERSITECH CORP INTERPRET THIS DRAWING IN ACCORDANCE WITH ASME Y14.5-2009 DIMENSIONING AND TOLERANCING STANDARDS	NOTES:	MATERIAL: SEE NOTES FINISH: SEE NOTES *DO NOT SCALE*			TITLE	SIZE	
					Super Stand Base w/ 48" rails, one 62", one 74" ext, & 24" tall		B
		THIRD ANGLE PROJECTION 	NAME	DATE	DRAWING NUMBER	REVISION	
			DRAWN	AMP	18 Mar 19	QSSB(48)(62)(74)-24	
			ENG APPR.				
		MFG APPR.			SCALE: 1:2	WT. (lbs):	
					4	SHEET 1 OF 1	