

D

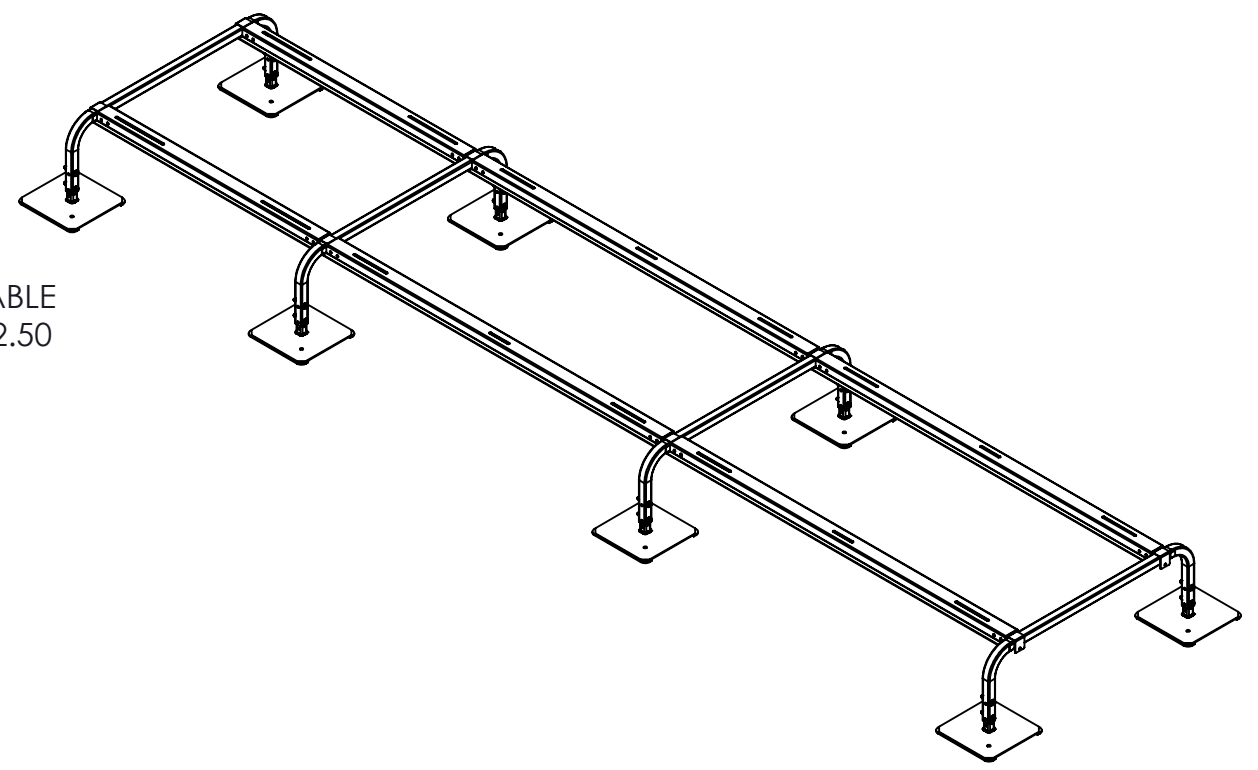
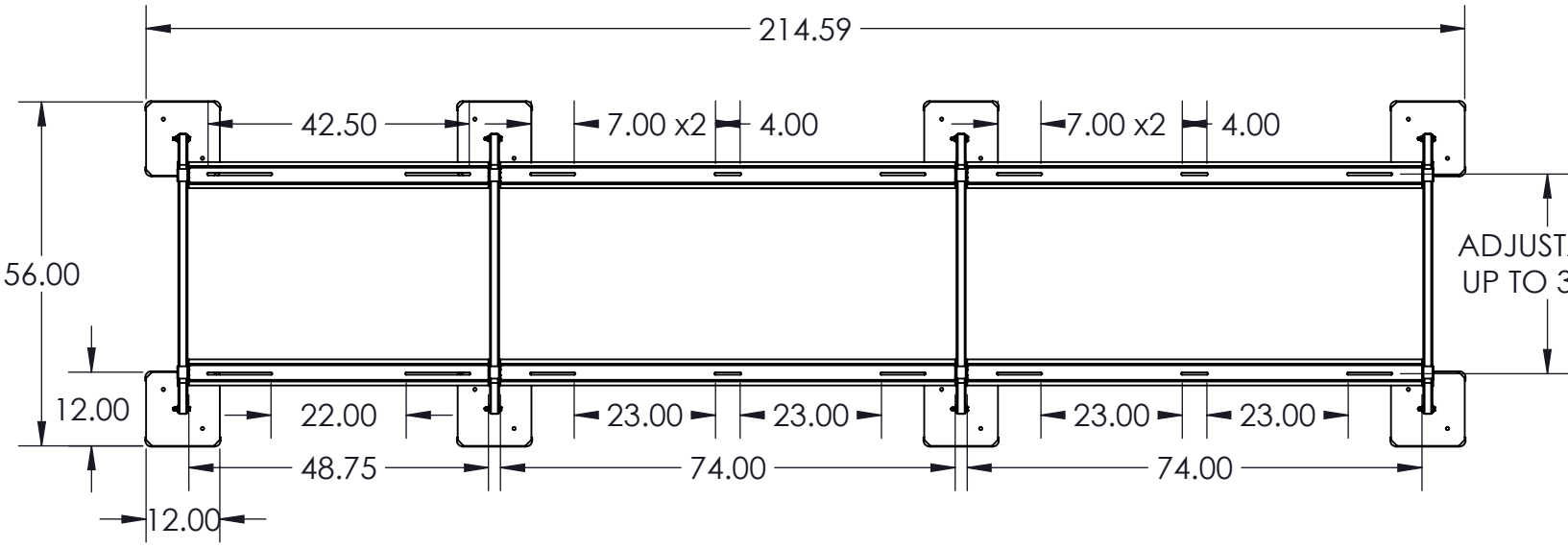

D

C

B

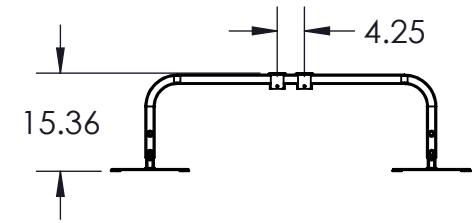
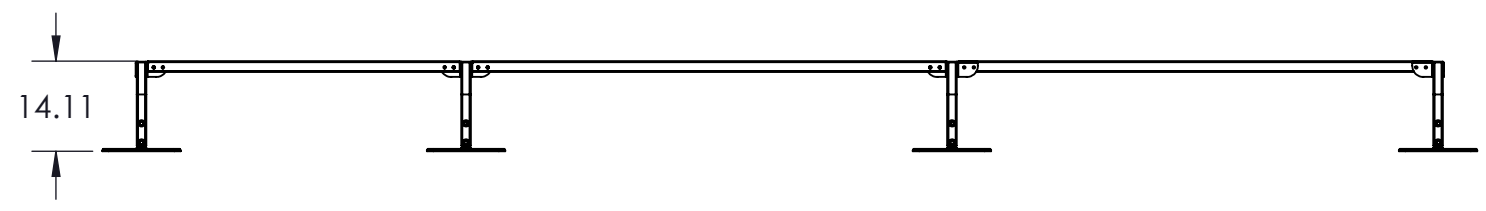

C

B

THIS UNIT CONSISTS OF:
(1) QSSB48-12
(2) QSSX74-12

A

ALL DRAWINGS AND WRITTEN MATERIAL CONTAINED HEREIN ARE THE PROPERTY OF DIVERSITECH CORP AND MAY NOT BE DUPLICATED OR DISCLOSED AT ANY TIME UNLESS APPROVED IN WRITING BY DIVERSITECH CORP

INTERPRET THIS DRAWING IN ACCORDANCE WITH ASME Y14.5-2009 DIMENSIONING AND TOLERANCING STANDARDS

NOTES:

MATERIAL: SEE NOTES
 FINISH: SEE NOTES
 DO NOT SCALE

THIRD ANGLE PROJECTION

DIVERSITECH

| | |
|-----------|-----------|
| NAME | DATE |
| AMP | 11 Mar 19 |
| ENG APPR. | |
| MFG APPR. | |

| | | |
|--|------------|--------------|
| TITLE | | SIZE |
| Super Stand Base w/ 48" rails, two 74" ext, & 12" tall | | B |
| DRAWING NUMBER | | REVISION |
| QSSB(48)(74)(74)-12 | | |
| SCALE: 1:2 | WT. (lbs): | SHEET 1 OF 1 |

A