

**PLAN VIEW RETRACTED**

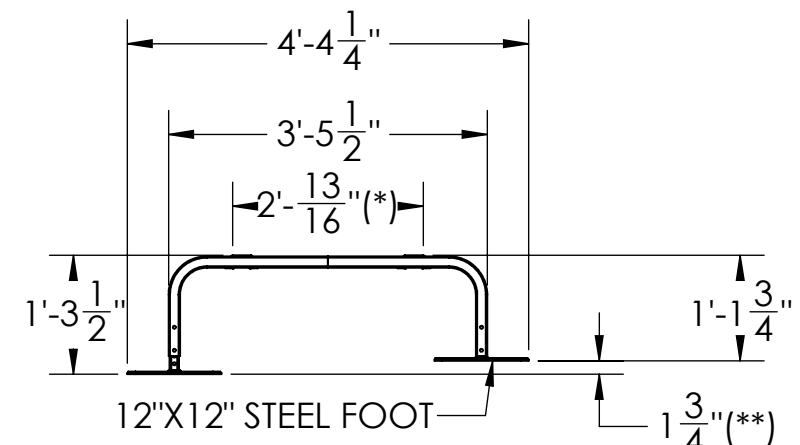

**END VIEW RETRACTED**

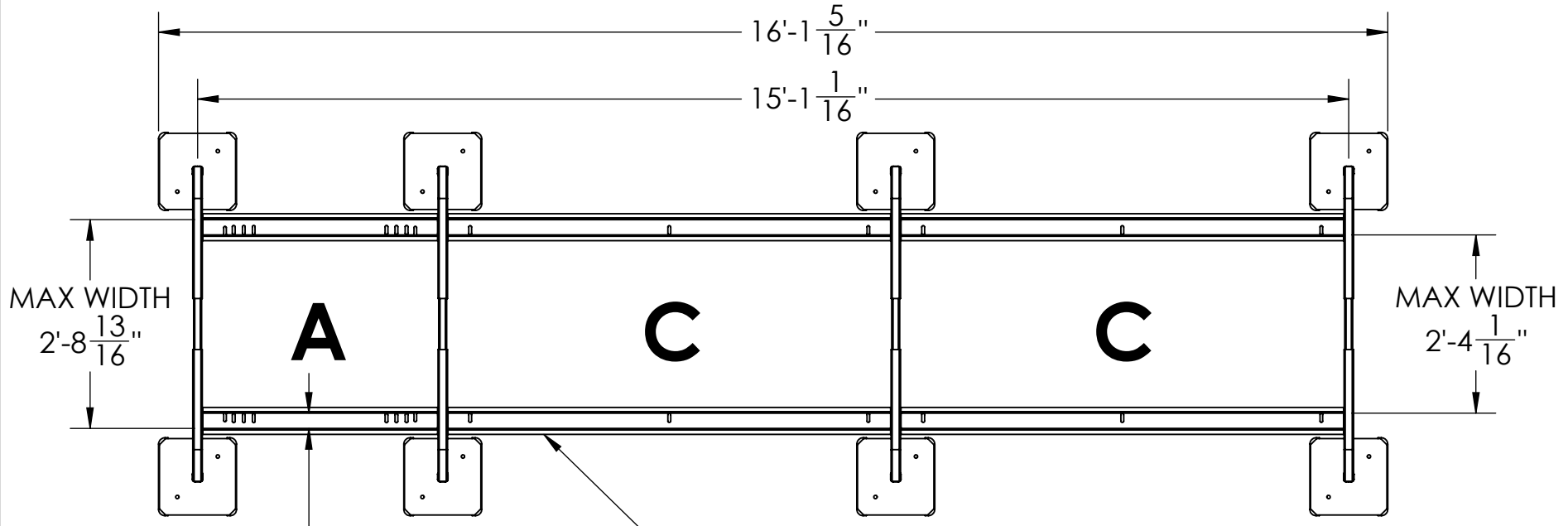

**PLAN VIEW EXPANDED**

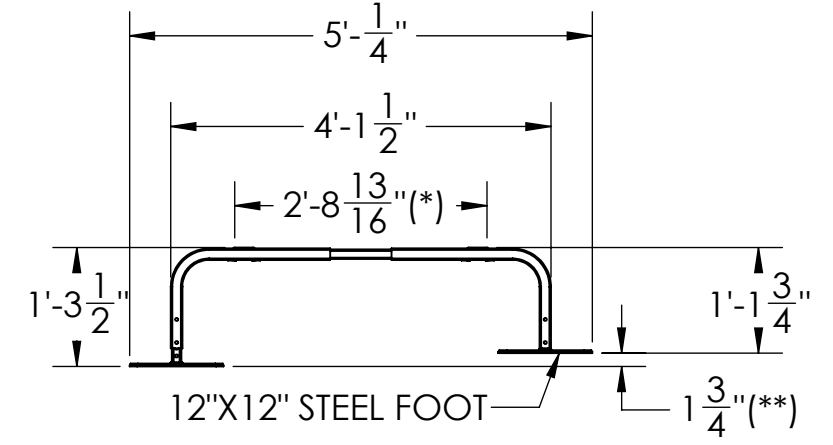

**END VIEW EXPANDED**

(\*) - WIDTH IS ADJUSTABLE IN 1" INCREMENTS  
 (\*\*) - HEIGHT IS ADJUSTABLE IN 1/4" OR 1/2" INCREMENTS UP TO 1 3/4".

**IMPORTANT NOTE: THE INSTALLER IS RESPONSIBLE FOR THETHERING AND BOLTING UNITS TO WITHSTAND WIND AND/OR SEISMIC LOADS.**

11 GAUGE CROSS RAIL TYP.

2 3/8" TYP.

UNLESS OTHERWISE SPECIFIED:  
 DIMENSIONS ARE IN INCHES [MILLIMETERS]  
 TOLERANCES ARE: ANGLES ±1.0°  
 FRACTIONAL SIZES X/Y ±1/64

INCHES	[MILLIMETERS]
X = ±0.1	[X = ±2.5]
.XX = ±0.01	[.X = ±1.3]
.XXX = ±0.005	[.XX = ±0.13]

THIRD ANGLE PROJECTION



CONFIDENTIAL - PROPRIETARY - DO NOT COPY THE INFORMATION SET FORTH IN THIS DOCUMENT AND RELATED INFORMATION IS THE CONFIDENTIAL PROPERTY OF DIVERSITECH CORPORATION, AND IS NOT TO BE COPIED OR REPRODUCED OR DISTRIBUTED IN ANY FORM WITHOUT PRIOR WRITTEN PERMISSION FROM DIVERSITECH CORPORATION. DO NOT SCALE DRAWING	MATERIAL: DWG. NO. 12" SUPER STAND - TYPE A-C-C MODEL NO. QSSS1013-12"	WEIGHT GMS. REV. <b>A</b> SHEET 1 OF 2
	DESCRIPTION	

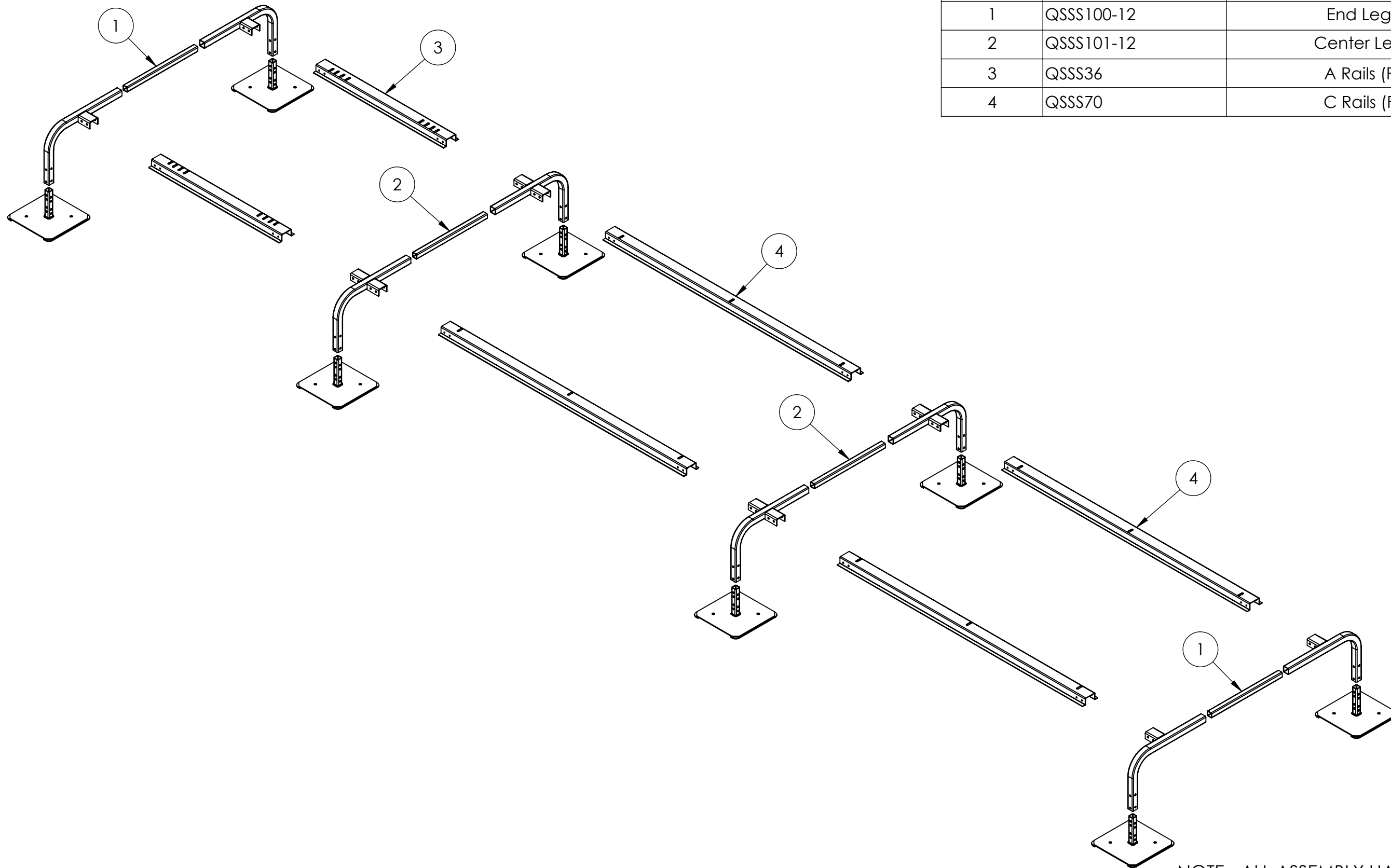

ITEM NO.	PART NUMBER	DESCRIPTION	Default/ QTY.
1	QSSS100-12	End Leg 12"	2
2	QSSS101-12	Center Leg 12"	2
3	QSSS36	A Rails (Pair)	1
4	QSSS70	C Rails (Pair)	2

NOTE - ALL ASSEMBLY HARDWARE IS INCLUDED

UNLESS OTHERWISE SPECIFIED:  
 DIMENSIONS ARE IN INCHES [MILLIMETERS]  
 TOLERANCES ARE: ANGLES ±1.0°  
 FRACTIONAL SIZES X/Y ±1/64

INCHES	[MILLIMETERS]
X = ±0.1	[ X = ± 2.5 ]
.XX = ±0.01	[ .X = ± 1.3 ]
.XXX = ±0.005	[ .XX = ±0.13 ]

THIRD ANGLE PROJECTION



CONFIDENTIAL - PROPRIETARY - DO NOT COPY  
 THE INFORMATION SET FORTH IN THIS DOCUMENT AND RELATED INFORMATION IS THE CONFIDENTIAL PROPERTY OF DIVERSITECH CORPORATION, AND IS NOT TO BE COPIED OR REPRODUCED OR DISTRIBUTED IN ANY FORM WITHOUT PRIOR WRITTEN PERMISSION FROM DIVERSITECH CORPORATION.  
 DO NOT SCALE DRAWING

MATERIAL:  
 DWG. NO. 12" SUPER STAND - TYPE A-C-C  
 MODEL NO. QSSS1013-12"

WEIGHT  
 GMS.  
 REV.  
**A**  
 SHEET  
 2 OF 2